



UBISENSE

Dimension4™

Accurate 3D tracking information is possible when only two sensors detect a tag, reducing the infrastructure requirements and minimizing cost. Advanced filtering algorithms select only the most reliable measurements from the excess of location data, providing an unmatched ability to cope with obstructed and reflected signals.

Contents

HARDWARE	3	18
UWB Sensor		
Sensor Types		
Network Connectivity		
Timing Distribution Unit		
Sensor Ingress Protection Ratings		
Sensor Mounting Bracket		
TagOptions		
Industrial Tag		
Mini Tag		
UB-Tag		
Tool Tags		
RTK-GPS Tag		
TagModule		
Industrial Tag Mounting Plate		
SOFTWARE		21
Location Software		
Software Components		
ARCHITECTURE		24
With TDU		
Without TDU		
DEPLOYMENT		27
Deployment Modes		
PRODUCT SPECIFICATION		
TagSpecifications		





HARDWARE

Dimension4™ measures both Time Difference of Arrival (TDoA) and 2-axis Angle of Arrival (AoA) of UWB signals in the same system, providing up to 3x more location information than comparable systems.

At Ubisense we've dedicated ourselves to perfecting a best-in-class, precision location system using Ultra Wideband (UWB) technology.

DIMENSION4™ is the result of decades of experience delivering industrial-scale, real-world solutions that pin-point the true 3D location, movement and identity of people and things in critical processes.

INTRODUCTION

Ubisense Dimension4 (D4) is a best-in-class precision real-time location system.

It consists of hardware, firmware and server-based software components that together have helped D4 become the most widely-deployed, high-accuracy and production-proven location system in the world.

Dimension4 is differentiated from other UWB location systems through unique capabilities built deeply into both the hardware and software layers of the system.



Enterprise Scalability

Implementing fog processing techniques for enterprise scalability and controls-ready real-time performance



Industrial Strength

System deployment and IT management tools for mission-critical reliability



Highest Reliability

The only system to measure both angle and time-of-arrival from tags for location precision and robustness



Lowest TCO

The best available battery lifetimes with batteries lasting as long as 15 years

- Handles 1000s of location updates per second
- Systems running with 1000s of sensors
- Proven 24/7 operation for over 10 years in harsh industrial environments



Ultra-Wideband Sensor

DIMENSION4 ultra-wideband (UWB) sensors are precision measurement devices, containing an array of antennas and ultra-wideband radio receivers. The sensors detect UWB pulses from Ubisense tags, allowing the Ubisense location system to find the tag positions with high accuracy.

Accuracy

By using UWB technology, the system's location accuracy is maintained even in cluttered, multipath-rich indoor environments. The Ubisense UWB location system is the only one capable of measuring both 2-axis Angle-of-Arrival (AoA) and Time-Difference-of-Arrival (TDoA) of tag signals, enabling it to generate accurate 3D tracking information even when only two sensors can detect the tag. This reduces the infrastructure requirements for an installation, minimizing costs while dramatically improving the reliability and robustness of the system.

Flexible & Scalable Installations

Ubisense uses a cellular architecture to scale from small to very large installations - large areas are covered by tiling them with 'cells' consisting of a small number of sensors working together.

Thousands of sensors can be integrated into a single enterprise-wide system to monitor an unlimited area and manage thousands of tags.

Sensors can be connected together in a variety of ways, allowing infrastructure cost to be traded against location accuracy in accordance with application requirements.

Ease Of Maintenance

Sensors are administered remotely over the Ethernet network.

Firmware is downloaded into the sensors over the network allowing them to be easily upgraded when new features become available.



Sensor Types

DIMENSION4 sensors come in two types:

A **directional sensor** designed for mounting along walls or along the edges of coverage areas (like an assembly line). This sensor tracks tags within the area in front of it and is normally oriented outwards.

An **omnidirectional sensor** designed for mounting in large, open spaces (like a warehouse). This sensor tracks tags in the 360° area around it and is normally oriented downwards.



Network Connectivity

Timing Ports

When configured in TDoA+AoA positioning mode, sensors must be synchronised with each other to within a fraction of a nanosecond. Sensors are synchronised using signals sent between them, either directly on dedicated timing cables, or on spare lines of the Ethernet cables via Timing Distribution Units (TDUs). Alternatively, sensors can run without any synchronisation in an AoA-only positioning mode.

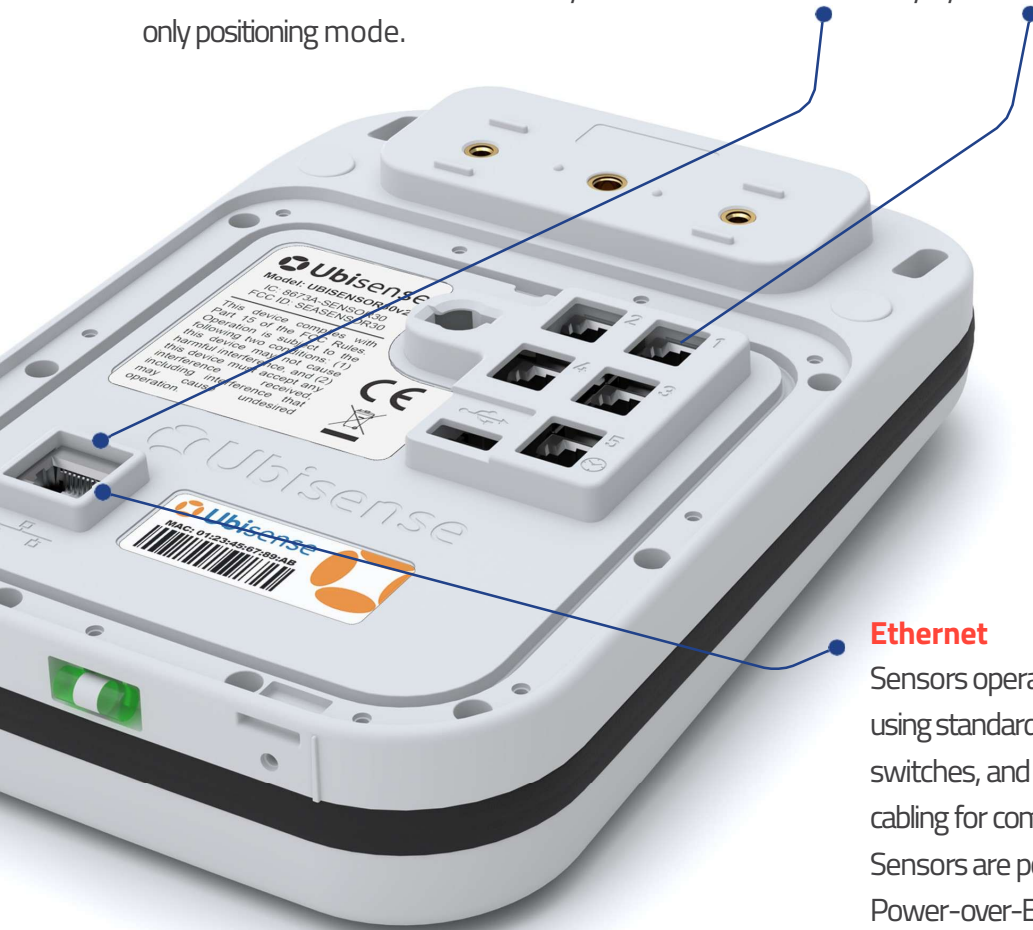

Ethernet

Sensors operate within an Ethernet environment, using standard network infrastructure such as Ethernet switches, and unshielded Cat5e structured network cabling for communication between sensors and servers. Sensors are powered through the network cable using Power-over-Ethernet switches.



Status LED

The status LED provides system and network status updates.



Timing Distribution Unit

The Ubisense **DIMENSION4** Timing Distribution Unit (TDU) is a 2U rack-mountable device that provides timing synchronisation support for up to 21 Ubisense sensors in a Ubisense sensor network. It reduces the number of long cable runs required for a sensor installation by combining the network and timing signals needed by each sensor onto a single unshielded Cat5e cable. TDUs can be chained to support larger systems.

The TDU has 21 ports to be connected to a Power-over-Ethernet (PoE) switch as well as 21 ports to be connected to sensors. Power and networking are passed onto these ports from the PoE switch, and the TDU injects an additional timing signal used by Ubisense sensors onto unused signal lines in the cable.



One port provides Ethernet networking and power (PoE) to the TDU, allowing it to be booted and managed over the network.

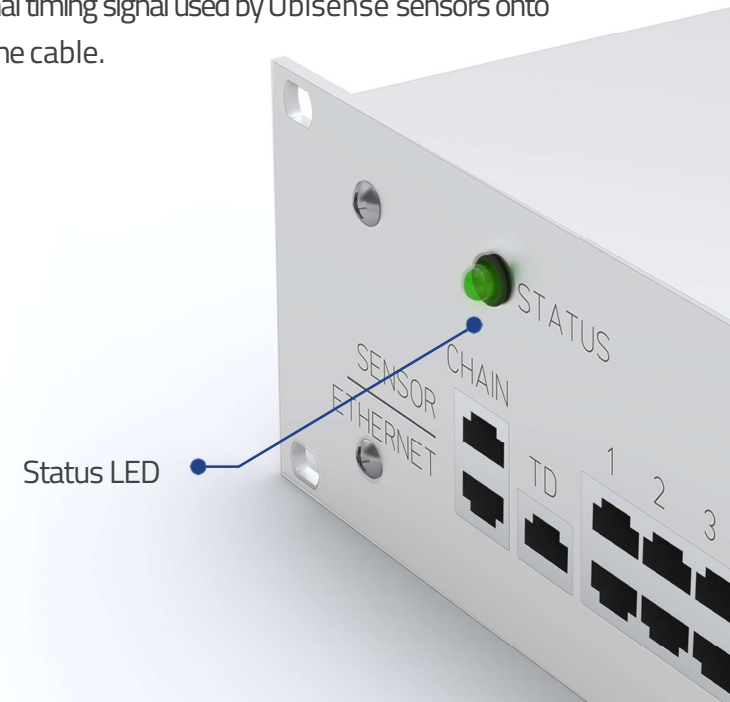

Status LED



Sensor Ingress Protection Ratings

There are three variants of the IP-rated **DIMENSION4** sensor: IP30, IP54 and IP69K. These have been designed for a variety of both indoor and outdoor scenarios and engineered to operate in both normal and extremely harsh industrial environments

The **IP69K** rated sensor has been designed for extreme outdoor operation in harsh industrial environments requiring protection not only against water and dust but also high winds, heat and cold. The sensor includes a rear cover with IP-rated push-pull connectors at the base of the sensor for extra protection against extreme elements.

The **IP30** rated sensor is intended for normal indoor operation where a standard level of protection against water and dust is required.



The **IP54** rated sensor is intended for challenging indoor environments. It has a cover on the rear of the sensor incorporating two brushes which are housed at the base of the sensor to prevent water splashes and dust from entering the sensor housing via the cable entry points.



Sensor Mounting Bracket

The Ubisense Sensor Mounting Bracket is a rugged and robust bracket for mounting any Ubisense D4 sensor. Made from glass-reinforced nylon, it is designed to withstand the harshest of environments, vibration and accidental knocks, both indoors and outdoors.

Sensors are often mounted in harsh outside conditions and at considerable height, so bracket adjustments may be accomplished single-handed, without the need for tools.

Two stainless steel captive bolts are supplied for fixing the bracket to the sensor, thus avoiding any chance of them being lost during installation. These may be supplied in marine grade stainless steel for use in highly-corrosive coastal and o-shore environments

Spirit level for optimum accuracy

Roll, Pitch & Yaw control



Tag Options

Ubisense tags offer our industry-leading accuracy and industrially-proven reliability when used with Ubisense Dimension4 and Ubisense AngleID hardware families.

Tags come in a range of form factors and ingress protection ratings to cover a range of tracking needs in harsh industrial environments.



Key Facts

- Tags are Ultra-Wideband (UWB) transmitters operating in the 6–8GHz frequency range.
- Compatible with the IEEE802.15.4f standard.
- Support programmable update rates of up to 30Hz; tags can change their update rate depending on whether they are stationary or moving.
- Provide best available accuracy when used in conjunction with Ubisense sensor infrastructure.
- Monitor battery health and report current status to the system.
- Very low power transmissions enable very long tag battery lifetimes. At 1Hz update rate, the Industrial Tag will last up to 15 years.
- The Industrial tag is available with integrated GPS and the UB-Tag simultaneously transmits UWB and BLE signals for greater flexibility.



Industrial Tag

The Ubisense **DIMENSION4** Industrial Tag is a small, rugged device that is intended to be attached to assets and allows them to be located to high accuracy in 3D in real-time. It is specifically designed for use in industrial sites where harsh environmental conditions will be encountered. In addition to its tracking capabilities, it includes additional features such as three LEDs for easy status identification, a motion detector to instantly activate a stationary tag and a push button to trigger events. It also has a replaceable battery.

Rugged & Adaptable

The Industrial Tag is designed to be rugged for use in harsh industrial environments. It is mechanically robust, dust- and water-resistant to IP69K, and can be securely mounted using a variety of attachment mechanisms.



The tag has a button to provide context-sensitive input to interactive systems. Applications can use the tag's location at the time the button was pressed to determine what action should be taken in response. For example, activating an item of machinery when the button is pressed, but only if the user is in a safe location.

Optional Integrated GPS

The Multi-mode variant of the Industrial Tag incorporates a SiRFstar-based GPS receiver. It continually attempts to use GPS to find its location. When successful, it relays the location back to the Ubisense location system using an on-board 2.4GHz radio.



Mini Tag

The Ubisense **DIMENSION4** Mini Tag is our smallest self-contained tracking tag, intended for high-accuracy tracking of smaller objects.

It is very rugged, dust- and water-resistant to IP69K, and includes additional features such as an LED for easy status identification, a motion detector to instantly activate a stationary tag and a magnetic reed switch to trigger context-sensitive events. It also has a replaceable battery.

A variety of mounting methods allow the Mini Tag to be securely attached to a wide range of objects.



Haptic Feedback Option

Ubisense **DIMENSION4** mini tags are available with haptic feedback integrated into the same small sized tag, useful for providing immediate feedback if the tag is worn or carried by a worker.



UB-Tag

The Ubisense **DIMENSION4** UB-Tag is a small, rugged device that is intended to be attached to assets and allows them to be located with high accuracy in 3D in real-time. It can simultaneously transmit Ultra-Wideband (UWB) and BLE signals allowing seamless tracking using either technology, allowing more flexible infrastructure deployment based on application accuracy requirements.

It is dust- and water-resistant to IP69K with an ultrasonically-welded enclosure and offers long battery lifetimes of over 11 years in continuous use. The battery is non-user-replaceable with the enclosure and components designed for recycling when returned to Ubisense.



Simultaneous UWB And BLE Tracking

The tag transmits UWB radio pulses which can be used by the Ubisense location system to find its position with high accuracy, even in cluttered, multipath-rich indoor environments. The tag can also transmit BLE signals, either as iBeacon- or Eddystone-format packets (on standard BLE 2.4GHz channels), or Quuppa-compatible positioning packets (on standard BLE or Quuppa proprietary 2.4GHz channels). This allows the device to be used for either low- or high-accuracy BLE tracking, in addition to its UWB location capabilities.

Long Battery Life

The UB-Tag has exceptionally long battery lifetime, operating for more than eleven years in UWB mode at a continuous 1Hz (1 update per second) update rate.



Tool Tags

The Ubisense **DIMENSION4** Tool Tag is a small, rugged device that, when attached to tools, allows them to be located to high accuracy in 3D in real-time. It is specifically designed for use in industrial sites where harsh environmental conditions will be encountered. In addition to its tracking capabilities, it includes additional features such as three LEDs for easy status identification, a motion detector to instantly activate a stationary tag and a push button to trigger events.

Tag Variants

The Tool Tag comes in two variants:

1. Head unit only. This is powered by the associated tool.
2. Combined head unit and replacement A-size battery integrated into a robust casing.

Rugged & Adaptable

The Tool Tag is designed to be rugged for use in harsh industrial environments. It is mechanically robust, and can be securely mounted using a variety of attachment mechanisms.



RTK-GPS Tags

The Ubisense **DIMENSION4** RTK Tag is a multi-mode device designed for indoor and outdoor location of vehicles such as forklifts, buses and trains. It allows better-than-bay-level location in real-time, both indoors and outdoors using a combination of ultra-wideband (UWB) and RTK-GPS signals in the same device.

Hyper Accurate Outdoor Location

The tag incorporates an RTK-GPS unit for centimetre-level outdoor positioning. It receives standard GPS satellite signals and RTK-GPS corrections from a local RTK-GPS base unit (sold separately) and is capable of positioning within 3cm CEP (2D). When a GPS position is successfully found, it relays the location back to the Ubisense location system using the 2.4GHz radio



Tags Module

The Ubisense D4 Tag Module provides the precise tracking capabilities of the standard Ubisense tags together with the ability to easily integrate that functionality into other devices. It is supplied with a 20-way (2 x 10) 1.27mm pin header, which provides for power supply, general input / output and serial data communication, enabling increased integration flexibility.

Certification

The Ubisense D4 Tag Module has received Modular Certification in the US and Canada, and is designed to meet plug-in radio module requirements in Europe. By following the instructions supplied with the Ubisense Tag Module, integrators will minimise the RF emissions testing required on their final product. Integrated into a robust casing.



Location Aware Devices

Dimension4 is already integrated into several production-critical industrial tools and devices supporting location-aware process control. This includes high-end torque tools, barcode scanners and tablets.

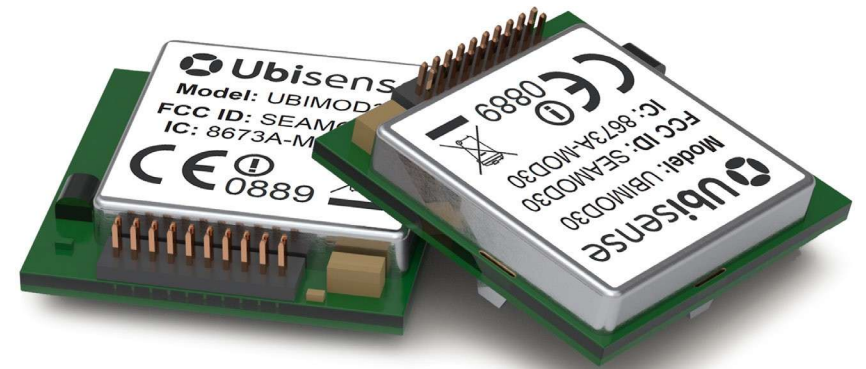

Integration Ready Features

The D4 Tag Module is intended for direct integration into other products. It is compact, includes all required antennas (permanently attached to the module), and has a 20-way expansion header that can be used to supply power to the device.

Furthermore, the header allows the module to communicate bi-directionally with a host device or external sensors and actuators.



Industrial Tag Mounting Plate

Ubisense tags incorporate a number of design features to allow temporary or permanent mounting to objects. The Industrial Tag features four mounting points for M4 bolts and two slots that work with industry-standard strapping or cable ties. On the underside are four concealed bosses that allow the tag to be screwed onto valuable items in a way that makes it harder to remove. This can be done with self-tapping 3mm screws for plastic.



With the optional Industrial Tag Mounting Plate additional mounting options become available.

Two M4 bolts for permanent attachment



The Industrial Tag is mounted to the plate via four stainless-steel M4 bolts (supplied), allowing the tag to be easily removed for maintenance.

Four M3 bosses for secure permanent mounting from the rear

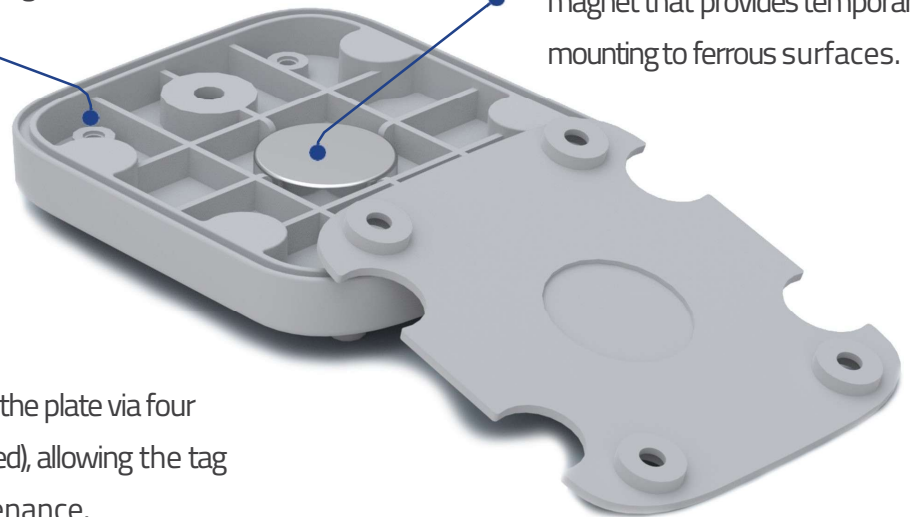

A flat surface for use with adhesive tape or industrial Velcro

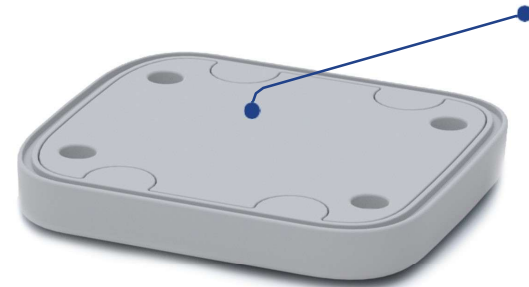

Support for an internal captive magnet that provides temporary mounting to ferrous surfaces.



SOFTWARE

Dimension4™ with SmartSpace® Platform is a comprehensive package including sensor firmware and server-based software components required to configure, coordinate and manage the Dimension4 RTLS

- Code running on the sensors
- A set of services that run on a networked Linux or Windows server or servers
- A set of Windows-based GUI configuration tools

Sensor Software

Scalability and real-time performance lie at the core of the **DIMENSION4** architecture, allowing users to deploy sensor systems that scale from micro-installations (small control systems running on a single machine) through to large sites with several servers and thousands of sensors and tags, with continuous and predictable behaviour.

- Management of initial sensor installation and configuration workflow
- Secure centralized management of configuration data for the sensor network
- Real-time coordination of the sensor network to share tag measurements between sensors
- Bayesian filtering of tag measurements to generate accurate tag location data
- Bulk storage and retrieval of measurement and location data for audit and review
- Health monitoring of the sensor network to support proactive maintenance



SmartSpace®

SYSTEM INSTALLATION	DEPLOYMENT OPTIONS	LOCATION PROCESSING	OPERATIONAL SUPPORT	STANDARDS	AUDIT & OPTIMISATION
Self-Configuration	Single Sensor Identification Mode	Group Arbitration	Sensor Firmware Management and Update	ISO24730 Interface	Bulk logging, storage and retrieval
Visual Configuration Tools & Workflow	Wireless Mode	Bayesian Optimal Estimation Filters	Centralised Configuration Store	IEEE 802.15.4f	Tracking Performance review tools
3D Site Visualisation	(Optional) Centralised Timing	Software Defined Cellular Architecture	"At the edge" Location Processing (FOG)	IEEE 802.15.4f LEIP	Location Health Diagnostics
	(Optional) Decentralised Timing	Application Specific Filter Creation		Combined Angles and TDOA Measurement	System Health Diagnostics

- System Installation – Components and tools that support efficient and accurate deployment of the D4 sensor system
- Deployment Options – Multiple configuration and operating modes for different tracking use cases and IT environments
- Location Processing – Real-time cellular management and optimization of sensor data using optimal estimation techniques
- Operational Support – Centralized management of sensor network configuration data, real-time coordination of live tag measurements between sensors and component-level operational support tools
- Standards – Standards-based support for on-the-wire integration, over-the-air transmission and UWB signal measurement
- Audit & Optimization – Storage, retrieval, review and analysis of sensor data for audit, review and preventative maintenance





ARCHITECTURE

Dimension4™ Architecture

Example Network Architecture - With TDU

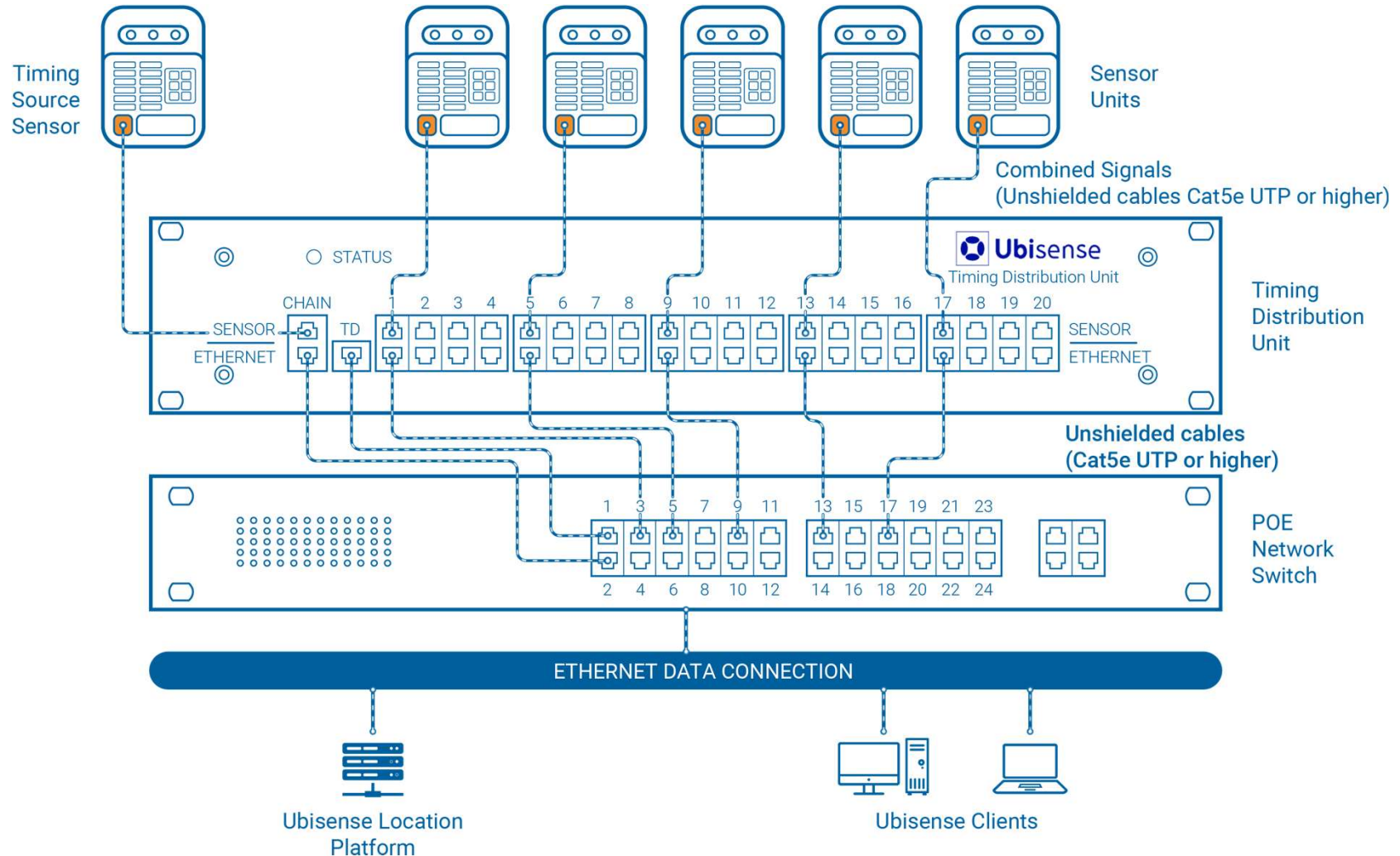



DEPLOYMENT

Dimension4™ Deployment

Deployment Modes



Full RTLS Mode

For mission-critical real-time process monitoring and control applications, Dimension4 is wired into your Ethernet network. Cat5e timing cables are run between sensors, or TDUs are used, for precise time synchronisation. This allows sensors to generate the maximum number of tag measurements by harnessing both angle (AoA) and time (TDoA) information, giving highest-possible 3D precision and redundancy in highly-cluttered and complex manufacturing environments such as assembly lines.



Wireless RTLS Mode

For non-mission-critical environments where running cables can be cost-prohibitive, Dimension4 can be run in a wireless back haul mode. Power is supplied local to the sensor and measurement data is shared across a wireless network to which all sensors are connected.

While sensors running in this mode continue to generate precise and reliable 3D locations, measurements are only based on angles (AoAs) as the lack of timing cable synchronisation means TDoA measurements are no longer possible.





Single Sensor Detection Mode

Some applications don't require accurate and continuous tag locations, and for these scenarios Dimension4 can be run in a single-sensor detection mode. In this configuration Dimension4 acts like a highly-reliable RFID reader, using angles and power level measurements to reliably locate tags which satisfy the detection parameters that have been set for the sensor.

Tags are given a location either coincident with the sensor or on a 2D plane located in the sensor's field-of-view

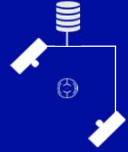

Deployment Modes

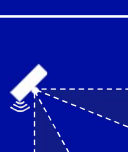
INFRASTRUCTURE LEVEL	TYPICAL USE	TYPICAL ENVIRONMENT	EXAMPLE ENVIRONMENT	INSTALLATION DEPENDENCIES									
				HARDWARE/SOFTWARE						DEPLOYMENT			
				Timing Distribution Unit of Hardwired Timing Sync Cables	Local POE Switches	Local Power	Wired Ethernet Network	Wireless Network	Server Running Location Platform	Survey of Sensor Location	Calibration of Sensors	Ubisense deploy/configure User	Deploy/Configure
Level 5: Full RTLS 	Critical real-time controls	Highly Cluttered, Production-critical areas	Assembly Line	<input type="checkbox"/>	<input checked="" type="checkbox"/>	<input type="checkbox"/>	<input checked="" type="checkbox"/>		<input checked="" type="checkbox"/>	<input checked="" type="checkbox"/>	<input checked="" type="checkbox"/>	<input checked="" type="checkbox"/>	
Level 4: Space RTLS 	Non-critical controls, Process Monitoring	Lightly Cluttered Storage Areas	Assembly Area	<input type="checkbox"/>	<input checked="" type="checkbox"/>	<input type="checkbox"/>	<input checked="" type="checkbox"/>		<input checked="" type="checkbox"/>	<input checked="" type="checkbox"/>	<input checked="" type="checkbox"/>	<input checked="" type="checkbox"/>	
Level 3: Full Wireless RTLS 	Non-critical controls, Process Monitoring	Lightly Cluttered Storage Areas	Line-side			<input checked="" type="checkbox"/>		<input checked="" type="checkbox"/>	<input checked="" type="checkbox"/>	<input checked="" type="checkbox"/>	<input checked="" type="checkbox"/>	<input checked="" type="checkbox"/>	
Level 2: Sparse Wireless RTLS 	Process Monitoring, Asset Monitoring	Non-cluttered Storage Areas Outdoors	Warehouse, assembly building			<input checked="" type="checkbox"/>		<input checked="" type="checkbox"/>	<input checked="" type="checkbox"/>	<input checked="" type="checkbox"/>	<input checked="" type="checkbox"/>	<input checked="" type="checkbox"/>	
Level 1: Single Sensor Detection Mode 	Asset Monitoring Local Control	Small areas, Outdoors	Small Building, Gate, Door			<input checked="" type="checkbox"/>	<input type="checkbox"/>	<input type="checkbox"/>	<input type="checkbox"/>			<input type="checkbox"/>	<input type="checkbox"/>



Tag Specifications

	UB-Tag™	Mini Tag	Industrial Tag	Tool Tag	Tool Tag Head Unit	Tag Module	RTK-GPS Tag	
Location Technology	UWB & BLE	UWB	UWB & Optional GPS*	UWB	UWB	UWB	UWB/GPS	
Power Source	Lithium Coin Cell	C-Size Lithium Cell	C-Size Lithium Cell	A-Size Lithium Cell	Powered By Host Device	Powered By Host Device	Powered By Host/ Battery Backup	
Battery life at 0.5Hz	>10 Years (UWB)	4.5 Years	>10 Years	>10 Years	N/A	N/A	N/A	
Battery life at 1Hz	>10 Years (UWB)	2.5 Years	>10 Years	>10 Years	N/A	N/A	N/A	
Battery life at 4Hz	tbc	0.7 Years	6 Years	3 Years	N/A	N/A	N/A	
Battery life at 8Hz	tbc	0.4 Years	3 Years	1.5 Years	N/A	N/A	N/A	
Dimensions	46x42x18mm (1.8x1.7x0.7")	54x40x14mm (2.1x1.6x0.55")	71x64x47mm (2.8x2.5x1.85")	108x39x31mm (4.2x1.5x1.2")	42x32x21mm (1.7x1.3x0.8")	24.5x24.5x9.1mm (1.00x1.00x0.36")	215mm x140mm x 70mm (8.5" x5.5" x2.8")	
Weight	21g (0.7oz)	35g (1.2oz)	128g (4.5oz)	104 (3.7oz)	22g (0.8oz)	5g (0.18oz)	697g (1lb 9oz) (including A-size battery)	
Temperature	-20°C to 70°C (-4°F to 158°F)	-40°C to 85°C (-40° to 185° F)					-40°C to 65°C (-40° F to 149° F)	
Humidity	0 to 100%	0 to 95% non-condensing					0 to 95% non- condensing	
Enclosure	Ultrasonically-Welded case	Polycarbonate (V0 -rated) Silicon Rubber Gasket	ABS/PC (V0-rated) Silicone Rubber Gasket	ABS/PC (V0-rated) Polyurethane Coating	ABS/PC (V0-rated)	None	ASA/Polycarbonate (UL V0)	
IP Rating	IP69K			Not Specified			IP67/IP69K	
Update Rate	Up to 30Hz						UWB: Up to 30Hz GPS: 1 per sec - 1 per 15 min	
Peripherals & Interfaces	LEDs Motion Detector Magnetic Reed Switch	LEDs Motion Detector Magnetic Reed Switch	LEDs Motion Detector Push Button or Magnet- ic Reed Switch	LEDs Motion Detector Push Button (Concealed)	LEDs Motion Detector Push Button (Concealed)	20 Way Expansion Header Motion Detector	N/A	



Sensor Specifications

	Standard Gain	Medium Gain	High Gain	External Antenna	Omni-Directional	Timing Distribution Unit (TDU)
Range	65m	100m	130m	up to 200m, depending on antenna gain	30m	N/A
Field of view	+/-80° in azimuth, +/-40° in elevation				360	N/A
Power Supply	Power-over-Ethernet IEEE 802.3af compatible (budget 15.4W per unit at the switch)					
Dimensions	IP30: 220 x 150 x 60 mm (8.7" x 5.9" x 2.4") IP54: 220 x 150 x 100 mm (8.7" x 5.9" x 3.9") IP69K: 220 x 150 x 90 mm (8.7" x 5.9" x 3.5")					48cm x 28.5cm x 8.7cm (18.8" x 11.5" x 3.4")
Weight	IP30: 720g (25.4 oz.) IP54: 860g (30.3 oz.) IP69K: 1100g (38.8 oz.)					2.7kg (6lbs.)
Temperature	-40°C to 65°C (-40°F to 149°F)					0°C to 60°C (32°F to 140°F)
Humidity	0 to 95% non-condensing					0 to 95% non-condensing
Enclosure	Protection levels IP30/IP54/IP69K ABS/PC (V0), UV Stabilized					2U 19" rack-mountable box
IP Rating / Connectors	IP30, IP54, IP69K: RJ45					N/A
Radio Frequencies	Ultra-wideband channel 6 – 7GHz					N/A
Certifications	US: FCC Part 15 FCC ID SEASENSOR30 Canada: RSS-GEN, RSS-210, RSS-220; IC: 8673A-SENSOR30 EU: CE					US: FCC Part 15 Class B Canada: ICES-003 EU: CE
Mounting Methods	Adjustable mounting bracket (Supplied) Safety Cable (Not Supplied)					





www.ubisense.com

globalenquiries@ubisense.com